A person in a dark suit stands on a globe with arms raised in triumph. The background is a dark blue sky with several glowing lightbulbs scattered around. The title 'Striving for Power Perfection' is written in a large, orange, serif font across the top.

# *Striving for Power Perfection*

An Initiative  
Toward Perfecting  
the Quality of  
Electric Energy Service

*Kurt Yeager*



**M**MUCH HAS BEEN WRITTEN ABOUT OPTIMIZING POWER SYSTEMS. IMPROVEMENTS are continually suggested and evaluated, and some are eventually implemented. But mostly the power system engineer's thinking is constrained by two anchors: the existing system and the view that technical solutions regarding power systems are bounded by central generation on one end and the meter at the consumer's facility at the other. This is a fundamental limitation on perfecting electricity service; that is, an electric energy system that never fails to meet, under all conditions, every consumer's expectations for service confidence, convenience, and choice. This will indeed result in the lowest cost system as repeatedly demonstrated by corporations, large and small, through the use of quality management principles. A fundamental requirement is therefore to eliminate the artificial limitations on service quality. In the context of meeting this requirement, the electric energy system must consider and incorporate all elements in the chain of technologies and processes for electricity production, delivery, and use across the broadest possible spectrum of industrial, commercial, and residential applications.

The most important asset in resolving the growing electricity cost/quality dilemma and its negative reliability, productivity, and value implications is technology-based innovation that disrupts the status quo. These innovation opportunities begin with the consumer. They include the seamless convergence of electricity and telecommunications service; power electronics that fundamentally increase reliability, controllability and functionality; and intelligent, high-power quality microgrids that utilize distributed generation, combined heat and power (CHP), and solar renewable energy as essential assets. This smart modernization of electric energy supply and service will empower consumers and, in so doing, revitalize the electricity enterprise for the 21st century. This focus on the consumer interface also reflects the relatively intractable nature of the highly regulated bulk power infrastructure that now dominates U.S. electric energy supply and service.

In addition to absolute quality, a second principle guiding achievement of the perfect power system is the ability to unleash self-organizing entrepreneurs to engage in the U.S. electricity enterprise. Their innovative leadership, guided by consumer opportunities, provides the most confident engine for quality transformation and enduring value improvement. Such initiatives have been typically stymied, however, by the rigidly regulated commodity supply-based U.S. electricity sector, barriers to entry, poor incentives, and a general lack of effective commitment and follow-through.

Today the U.S. electricity sector faces a fundamental life-cycle inflection point. Consumers, communities, and utilities alike are confronted with the painful reality of rapidly rising electricity costs driven by fuel prices, pent-up infrastructure needs, and expanding environmental requirements. The resulting unavoidable need for major electricity rate increases is fundamentally changing the business-as-usual culture that has dominated the regulated utility industry for decades. In addition, the growing demand for clean, green energy is being fundamentally thwarted by an obsolete analog electromechanically controlled electricity supply infrastructure. This "perfect storm" of converging issues provides an unprecedented window of opportunity to encourage and rally both new entrants and existing stakeholders around an innovative blueprint and confident road map for achieving the perfect power system. The emphasis by the Galvin Electricity Initiative is on creative outside-the-box thinking that can achieve maximum consumer value through the application of an array of emerging innovative technologies, together with well-established continuous improvement methods that emphasize service quality.

### **The Perfect Power Initiative**

Phase One of the Galvin Perfect Power Initiative defined a set of four generic electric energy system configurations that have the potential to achieve perfection, together with the corresponding innovation opportunities that are essential to their success. Each candidate configuration reflects

a distinct level of electric energy system independence/interconnection from the consumer perspective. In so doing, these configurations address, in a phased manner, the fundamental limitations to quality perfection in today's centralized and highly integrated U.S. electric power system. They also provide a variety of new avenues for engagement by entrepreneurial business innovators.

The four generic system configurations are: a) device-level (portable) systems serving a highly mobile digital society; b) building-integrated systems, which focus on modular facilities serving individual consumer premises and end-use devices; c) distributed systems (Figure 1), which extend the focus to local independent microgrids, including interconnection with local power distribution systems; and d) integrated centralized systems, which fully engage the nation's bulk power supply network. These configurations should be considered as a complementary series rather than as competing systems.

These perfect power configurations provide five basic functionality advantages. They

- 1) eliminate consumer electricity service interruptions and maximize energy efficiency
- 2) minimize the cost of electricity service by optimally integrating clean local power resources with those of the bulk power system at all times
- 3) provide varying "octane" levels of digital-grade power to meet individualized consumer needs

- 4) expand consumer service value in terms of demand-response, metering, billing, energy management and security monitoring, among others
- 5) enable energy-smart appliances, power-market participation, and consumer-controlled distributed generation and storage.

In this regard, each configuration reflects a milestone on the consumer's path to comprehensive power system perfection. For example, integrated centralized systems reflect the greatest ultimate potential to be robust over the widest range of conditions. On the other hand, the building integrated microgrid systems, by virtue of their modular independence and greater near-term commercial implementation potential, provide the most immediately demonstrable service perfection capability. This configuration will also immediately facilitate greater energy efficiency, demand response, and productivity; incorporate a much more robust portfolio of distributed, CHP, and renewable energy resources; and significantly reduce environmental impacts.

In addition to defining the development of these plausible generic perfect power system configurations, a set of primary "nodes of innovation" were identified that are essential to the ultimate perfection of these configurations. These include power electronic controls, distributed generation and storage, comprehensive sensors, computational capabilities, communication, smart building systems, and efficient

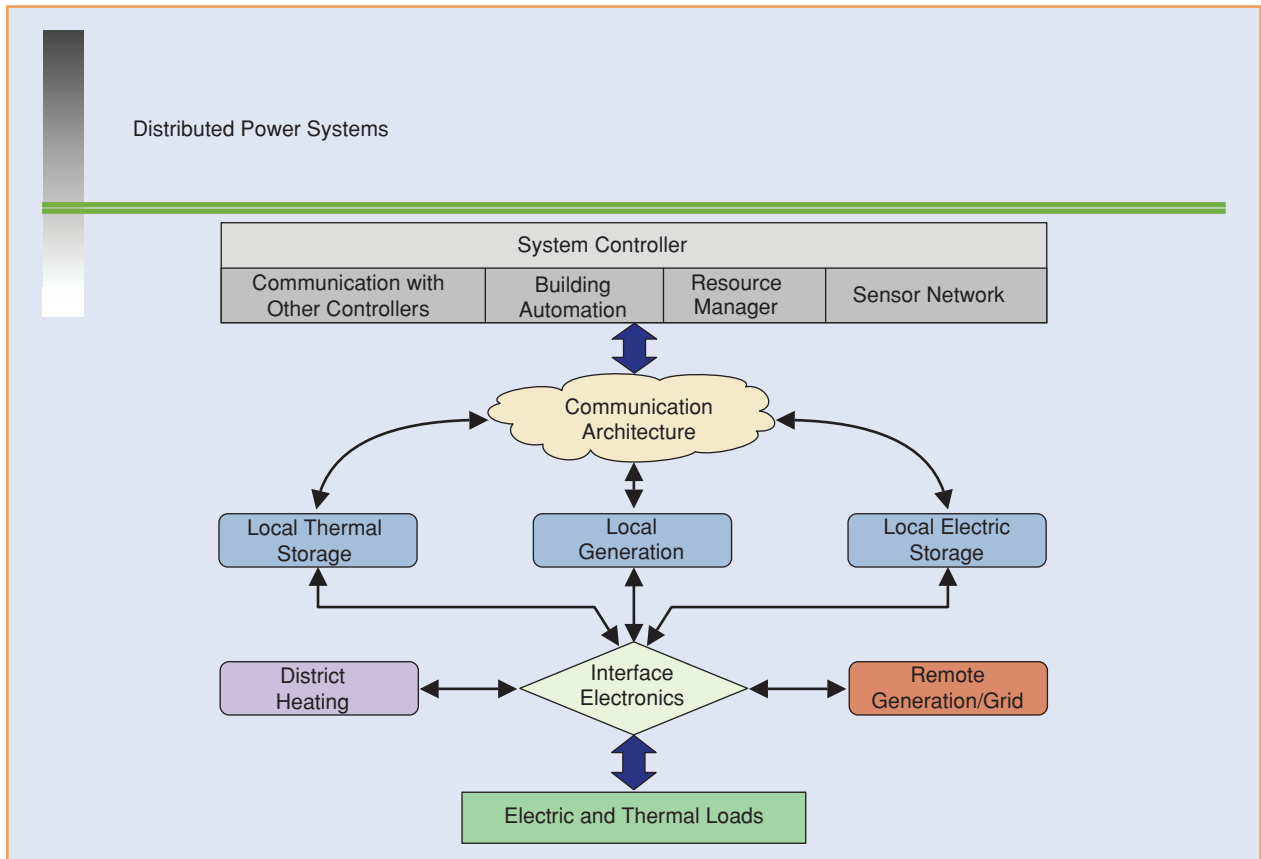

figure 1. Overview of distributed power systems.

electronic appliances. Within each of these innovation nodes, technologies that will enable system performance progress were also identified and the specific performance gaps for these technologies were defined.

In Phase Two, these results were expanded and refined into specific microgrid implementation blueprints, business templates, and quality management plans for achieving and maintaining unqualified perfection in 21st century electric energy supply and service. The result provided a comprehensive system engineering and business package supporting confident, prompt commercial implementation.

The brain and nerve center of the perfect power microgrid configurations is the electronic system controller. It is responsible for enabling the functionality advantages that maximize consumer value and optimizing the microgrid's operation. In effect, the system controller provides a decentralized decision-making capability that instantaneously balances electricity demand and supply coming from both the distributed generation and storage within the microgrid and the bulk power distribution feeder. The system controller uses the real-time market prices of electricity plus demand reduction requests to determine the amount of power that the microgrid should draw from the distribution feeder, thus optimizing the microgrid power's production capabilities. The system controller also controls the voltage and frequency of microgrid power during transient conditions, thus ensuring absolute reliability and power quality at all times.

Phase Two of the Galvin Electricity Initiative was conducted by a multidisciplinary team including Keyworks, EPRI Solutions, GF Energy, Strategic Decisions Group, and a collaborative network of independent technical and business experts. The Juran Center for Leadership in Quality at the University of Minnesota also developed perfect power quality leadership and management handbooks and courses. These recognize the fundamental importance of the human dimension in achieving results of uncompromising quality in any endeavor.

The Phase Three comprehensive application of the Galvin Perfect Power System architecture is being initially conducted on the campus of the Illinois Institute of Technology (IIT) in Chicago (Figure 2). IIT highly values perfect power. The campus is also located within the PJM independent system operator (ISO) control area. This provides an opportunity for IIT to generate significant revenue from the distributed generation assets installed throughout the campus. This opportunity results from the ability to eliminate power failures and leverage on-campus generation to provide auxiliary power services for the PJM ISO. Equally important are the unparalleled research opportunities that the perfect power microgrid system enhancement can provide to the university.

IIT aims to configure the campus electricity distribution system using the Galvin perfect power microgrid configuration to provide up to 12 MW of firm demand response and to

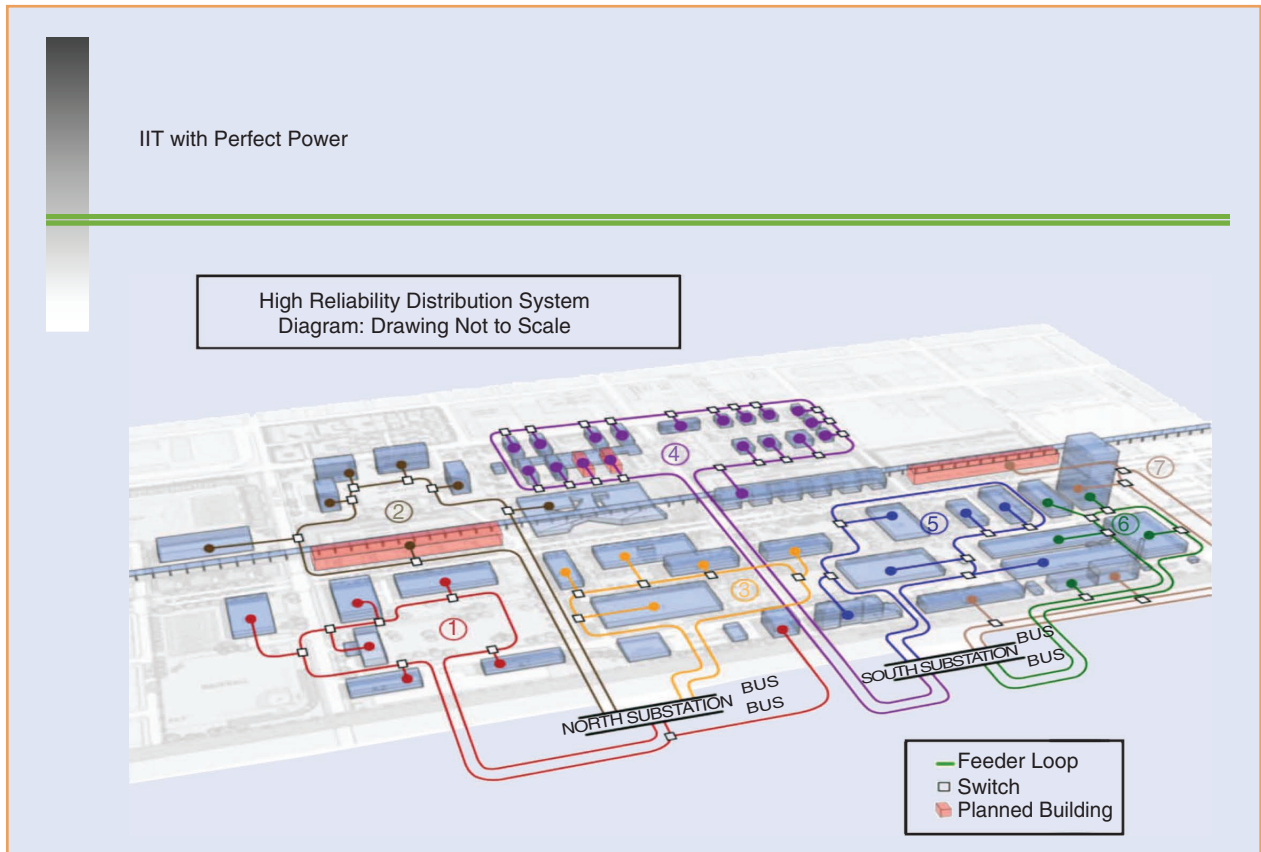

**figure 2.** Implementation of the perfect power system at the Illinois Institute of Technology in Chicago.

“island” the entire campus to take full advantage of real-time electricity pricing. The on-campus generation will be used to hedge peak electricity prices while enabling IIT to participate in both spinning reserve and day-ahead power markets. This capability need only be utilized 500–1,000 hours a year, yet the revenues will rapidly more than offset the investment needed to build the perfect power system at IIT. This system design, actively engaging Commonwealth Edison and the PJM ISO as well as IIT, provides a compelling example of the new electricity paradigm. Here, utilities and consumers work together to build local perfect power microgrids that best serve the economic and service quality interests of all parties. Recognizing the importance of this prototype to national smart grid implementation, the Department of Energy has also awarded a multimillion dollar grant to IIT for its perfect power microgrid and associated R&D initiatives.

The perfect power prototype at IIT leverages a new high reliability distribution loop system design that provides redundant electricity service to each building. Any fault can be isolated without interrupting power. IIT has also embarked on a major building energy efficiency upgrade program to help offset on-peak consumption. Further efficiencies plus carbon reductions will be achieved through the use of on-site renewable energy as an integral part of the campus microgrid. The system includes intelligent switching and breaker coordination technology that enables rapid assessment and isolation of faults. This perfect power microgrid will be managed by an electronic system controller that monitors and trends critical parameters to determine the system state and to continuously maintain it within the specified limits of operation. This self-healing system is thus capable at all times of automatically anticipating and responding to external disturbances and failures.

## **System Design Factors**

The foundation for an affordable, optimized perfect power system is to first focus on the energy efficiency of energy-using equipment (the end-use loads). Energy efficiency allows for overall long-term reduction of energy use and to a lesser extent reduction of peak demand. Demand response is also important. Demand response is the term for systems that enable energy users to receive information on time-varying electricity prices and/or capacity constraints and that the user has the ability to reduce or shift load in response to the information. Minimizing demand via energy efficiency and demand response means that the size of local or on-site generation and energy storage can be minimized, keeping costs down.

As part of assessing alternative design configurations for reaching a perfect power system, the research team identified several important technical design features, as discussed in the following sections.

### **Energy Efficiency and Reduced Energy Consumption**

Focusing on energy efficiency and reduced energy consumption is a key factor in achieving perfection since reducing the

energy demand allows other, more expensive system components such as generation and storage to be downsized. Reducing energy and power requirements also makes it easier to maintain reliability when faced with sudden supply interruptions or long-duration outages.

Although increased energy efficiency typically increases capital and installed costs, the relative increase depends to a great degree upon the experience of designers, builders, and installers. We have found that the incremental costs for an energy-efficient new building that meets the LEED Platinum standard hovers around +2%. (LEED is the Leadership in Energy and Environmental Design Green Building Rating System of the U.S. Green Building Council.) The reason the percentage increase is not higher is that, in new construction, using less energy can enable downsizing building systems and structures besides the on-site power system. These include smaller heating ventilating and air conditioning (HVAC) systems, fewer light fixtures, reduced water treatment facilities, and so on. The capital savings from such smaller systems helps compensate for the higher costs of energy-efficient equipment and design. And the trend in efficiency costs at the building level appears to be on a downward trend. According to an analysis of expert forecasts, the few percent in increased building costs could diminish to \$0 within five to ten years.

### **Connection to the Conventional Power Grid**

Connection to the conventional power grid enables levels of reliability (and affordability) required for a perfect power system. The outage rate of distributed generation resources is such that facilities should maintain a connection to the conventional power in the optimized power system.

To receive reliable power service, maintaining an existing connection to the grid will almost certainly be desired by consumers. The modern transmission grid and energy delivery system rely on a vast array of individual generators to maintain the electrical supply to customers. The advantage of this approach is that there is significant redundancy built into the system. Typically, the failure of one generator in the conventional power system will not cause a supply failure, since many other generators are available to meet the load.

Conversely, building-integrated power systems often use one or two generators so there is much less redundancy in the on-site power system than in the conventional power system. If there are multiple on-site generators, they are sized to meet the aggregated load, with each generator supplying a fraction of the power needed. Since on-site generators have a relatively high outage rate, systems often rely on the traditional energy delivery system to provide backup to the on-site generation. If the on-site generator fails, the energy delivery system is available to meet the load and a long duration outage is avoided.

Since adding multiple generators to the on-site system to boost redundancy is usually uneconomical, the connection with the conventional power system is needed. At a minimum, two on-site generators, both sized to meet the full

local load, are required to even approach the reliability of the conventional power delivery system. Often, three or more generators sized for the full load are required.

### **Access to Real-Time Pricing**

Consumers need to receive signals that reflect the actual price of electricity. The actual price of electricity fluctuates in response to supply and demand. But in today's regulated utility system, few consumers have access to the actual, real-time price of the electricity they are using. Only a small number of large customers get advanced information about hour-ahead or day-ahead prices. Instead, most electricity consumers, certainly the residential ones, pay the utility power provider bill that amounts to an average of the price of the electricity they actually used during a given period. A month later, they get an opaque bill that provides little guidance on how to use electricity more efficiently.

Numerous demonstration projects and commercial applications have shown that changing this equation results in substantial consumer behavior change, with a measurable effect on their electric bill. Simply put, consumers who know what they are paying for, and when, both use less and pay less for what they do use than do those who are not informed. The report draws on numerous studies showing that the reduction in peak- and overall-demand energy use has larger societal and environmental benefits as well.

Several factors have kept this transparent pricing structure from being made widely available. Much of the technology that exists today to understand and manage energy use is cumbersome and expensive, though there are many exceptions. While some commercial markets might be willing to invest more time and money into these technologies, the products have not yet evolved to meet the need. If only 40% of residential customers begin managing their energy load (about the same percentage as who have cell phones), we will see a major reduction in electricity demand.

### **Adjusting to Local Conditions**

Local climate and energy needs will dictate the components and features that should be included in the local building-integrated power system design. No one system configuration is right for every application, nor is just one configuration *the* perfect power system. Multiple variations are possible and necessary. For example, installations in cold climates will need to optimize thermal production and thus may upgrade to a large generator or opt for some supplemental heat generation such as a more traditional boiler or solar thermal system. Typically, these systems are sized to meet thermal demand. Conversely, designers of installations in warm, sunny locations may decide that the local heat and power generation can be downsized in favor of adding photovoltaic arrays to the system, since their thermal needs are relatively low.

### **Allowing for On-Site Needs**

Adequate space must be available at a facility to install an on-site power system. Planning for on-site generation and

storage in the building design phase (even if the system isn't immediately installed) helps reduce installed costs of an on-site power system.

### **Distributed Generation**

Many types of distributed generation technologies can be used in single buildings or in microgrids serving multiple facilities. A technology that has been in use for 100 years, the internal combustion engine, is available for on-site generation, and newer, commercially available technologies such as photovoltaic cell arrays and microturbines are also readily available. Fuel cells are another option, albeit still more expensive than other options. Other "green" generation technologies such as renewable technologies including wind generators can also be applied, although their siting and size requirements make them applicable only in specific settings with the right natural resource conditions, climate, and building density.

### **New Storage Technologies**

Many types of energy storage technologies are available for storing power, with lithium-ion batteries one of the most promising. For electrical storage, lithium-ion or lead acid batteries are commercially available. Storage technologies that show promise for future mass market entry include ultracapacitors, flywheels, compressed air storage, and super magnetic energy storage. Lithium-ion batteries have great potential for use in building-integrated power system and microgrid applications, due to their high cycle life and the fact that research on improving their performance is being conducted for electric vehicle applications. For the various engineering and economic analyses done for the Galvin Electricity Initiative, lithium-ion batteries were used as part of configurations examined.

### **Computational Enhancements**

Sensing, communications, and advanced computational ability are of great importance at all levels of a perfect power system. At each level (individual device, building, or microgrid), a network of sensors, monitors, and meters is required to feed operational information to controllers to ensure optimal system performance. Computational prowess is required to ensure that real-time, error-free calculations can be performed to enable required energy and reliability performance. Since reliability is primarily assured at the local level, the computational ability is needed for on-site energy management and system operation. Moreover, operation according to customer preferences in response to price or reliability signals from the conventional power delivery system are enabled.

### **System Controller Software**

System controller software will be a "lynchpin" component of the perfect power system. Microgrid system controllers with software that can address all functions and constraints on the system and automatically manage operation of each



portion of the system are needed. No such “off-the-shelf” control capability exists today. Investment in developing a fully functional, commercially available system controller is needed to ensure the development of building-integrated power systems and microgrids that can constitute the perfect power system(s).

### **CHPs Are Key**

CHP systems are one of the keys to economical building-integrated power systems and microgrids. In the CHP system, heat and electricity are generated simultaneously in a single integrated system. This is more efficient than separate production of heat and electricity; CHP system efficiencies can be greater than 70%, as compared to central generating plants that average about 33% efficiency. In the CHP system, heat is recovered that is normally wasted in conventional power generation, and this heat can be used for end-use requirements such as water heating, process heating, steam, or cooling. Instead of wasting the heat produced during electricity generation, its value is captured.

Applying CHP in microgrids that serve facilities with high thermal energy use enhances the economic viability of the microgrid. For instance, when assessing the value of a mixed-use microgrid, which is comprised of multiple building and facility types, the research team found that value is greatly enhanced by incorporating a hospital. The team estimated that a mixed-use microgrid with a hospital that employs today's best technology can offer a benefit/cost ratio of 34 to 1.

### **Premium Power Parks**

A high reliability power park, also known as a premium power park, is a near-term microgrid application that can yield high benefits today. A high-reliability power park is an industrial or commercial facility/office park that provides a guaranteed level of power reliability to tenants. The level is far more stringent than the 99.9% reliability available through the conventional power grid. Rather than today's “three nines” of reliability, as 99.9% is known in the parlance of the power industry, many microprocessor-based high-tech industries and businesses need “nine nines” or 99.999999% reliability. Even brief outages or power quality problems such as voltage sags or spikes can cause production losses or equipment problems, which can cost millions of dollars annually. These parks incorporate state-of-the-art technology to ensure protection of sensitive equipment and processes. The Galvin Electricity Initiative research team's modeling of a microgrid for a premium power park reveals a benefit/cost ratio of 26 to 1 for today's high-reliability power park microgrid.

### **Web-Enabled Management**

The presence of the Web and increasingly popular Web-enabled energy management systems will aid in the evolution of perfect power systems. This transition is driven by emerging technologies now focused mostly in the comfort,

security, and entertainment space. These technologies include low-cost communications, wireless and wired, IP standardization, and low-cost mesh sensors and modules using emerging protocols like Z-Wave and ZigBee. In the commercial markets, there are enormous changes underway that allow building owners to manage their electricity loads in single buildings and in multiple locations intelligently and cost effectively. Combined with an expanded focus on green building design, new HVAC technologies, enhanced energy storage technologies for energy-intensive building applications, and higher performance decentralized generation and heat and power applications, we expect to see that 40% of the sector could become fully Web-enabled and consumer-controlled within five years.

### **The Most Productive Investments**

The research team identified the investments in technology and other areas that are most likely to yield the best returns, enabling the achievement of perfect power. Modeling revealed that initial costs are a major factor in deriving value from the optimized electric power delivery system. Such a finding is intuitive and rather general in nature because it applies in virtually every case; however, the modeling and assessment enables sufficient detail on the relationship of capital costs and benefits to the end user to identify which elements of an integrated power system require further technical or market development and investment.

- ✓ Development of a fully functional, commercially available system controller. The controller, as the brains and communication hub of the perfect power system, is essential to optimal system performance. The first step in creation of a commercial “off-the-shelf” system controller, rather than a “boutique” product created for each project, is development of software that can be incorporated into advanced hardware for deployment.
- ✓ Best practices in building design should include mechanical/electrical tie-ins and provision of space for distributed system infrastructure. This could also have a major influence in reducing the installed costs of combined heat and power systems, which typically feature internal combustion engine generation.
- ✓ Lower-cost, large-scale battery storage. Batteries are one of the key microgrid and building-level system technologies in which funds can be productively invested. One of the promising targets for this is reaching an installed cost of US\$400–1,000/kW for lithium-ion batteries, compared to a 2006 installed cost of US\$1,500 to \$2,000/kW. Value modeling shows that a 50% reduction in energy storage capital costs of lithium ion batteries can yield US\$1–\$10 million in consumer value realized annually with certain microgrid configurations. Reaching the price targets will require research, development, and

demonstration investment in the range of US\$150–\$300 million, according to industry experts interviewed by the Galvin research team.

- ✓ Less expensive photovoltaic cell arrays. Photovoltaic module production at US\$3/W by 2012, compared to close to US\$5/W today, would likely take an investment of US\$1 to \$2 billion. This investment is being made as the industry rapidly expands. Moreover, there are other essential factors to implementing photovoltaic cells, which are related to the policy/regulatory barriers listed in the “Conclusions” section. One is net metering, a metering practice in which utilities measure and bill for net electricity consumption, accounting for electricity delivered via the conventional grid as well as power produced at the customer’s premise that flows into the main grid. A second factor is interconnection rules that do not penalize customer-owned photovoltaic systems.

## Conclusions

Entrepreneurial prototypes of the Galvin perfect power microgrid system architecture are being initiated in a variety of commercial settings that focus both on implementing specific perfect power business opportunities and on pursuing the various technical innovation breakthroughs identified in the course of the Galvin Electricity Initiative. A variety of specific commercial prototype demonstration sites are now being evaluated and site-specific designs, together with the appropriate implementation policy recommendations, will complete the commercial technology transfer of the initiative’s results.

In open markets, these comprehensive technical and business opportunity results would be an entrepreneur’s dream, promising rich commercial opportunities. Unfortunately, regulated power industry policies and governance still impede the superior value propositions that the Galvin Perfect Power Initiative promises. Economists and long-standing business experience offer clear guidance on how to stimulate innovation and incite industry toward optimal performance. The key is free enterprise where industry is exposed to market forces. This requires that there are no barriers to entry, prices send clear and accurate price signals, there is an absence of subsidies, and predatory practices are prohibited.

Demand response is an essential part of the market-based solution to the fragility of the nation’s bulk power grid. This fragility is apparent whenever electricity demand peaks or when even a small part of the system is damaged. An important dimension of the Galvin Perfect Power system is therefore to provide consumers the innovative technology that will enable them to take maximum advantage of the demand response opportunity while providing the utilities the ability to instantaneously tap this resource. Again, however, regulatory treatment is a key issue. In spite of its advantages, demand response still suffers from second-class citizenship in most regulated

resource allocation schemes. Although the same number of megawatts can be provided through demand response as from a peaking generation resource, it typically receives discouragingly different regulatory treatment at the state level. What are needed are concerted efforts such as the Galvin Electricity Initiative to remove the barriers that discourage efficient technologies and entrepreneurs throughout the electricity value chain.

In addition to the Web site [www.galvinpower.org](http://www.galvinpower.org), a comprehensive communications effort has also been launched that includes professional and technical publications, popular media articles, a “best-seller” book, and engagement of influential opinion leaders who are committed to the achievement of the perfect power system. This effort is intended to raise public appreciation of the capability to transform the reliability and value of electricity service through innovative, consumer-focused, power system advancements.

Modern society is increasingly dependent on electric energy, and it expects individualized service that enables intelligent control of energy consumption with a premium on reliability and environmental performance. Transforming to a consumer-directed energy service capability will change the business dynamic of the U.S. electricity enterprise from one of simply providing electric energy as a bulk commodity to offering a portfolio of individualized smart services of far greater value. This consumer-focused quality transformation will also serve to restore innovation and investment and resolve the growing vulnerabilities facing the nation’s regulated bulk electric energy infrastructure. This quality transformation is expected to reach the tipping point nationally over the coming five years. This will result from the combination of inexpensive, pervasive Web-based enabling technology and widespread implementation of demand response capabilities. Rapidly rising electricity costs and the resulting politically unpalatable rate cases will also encourage utilities and regulators alike to foster this transformation as a matter of enlightened self-interest, thus reversing their long-standing resistance.

## For Further Reading

C.W. Gellings and K.E. Yeager, “Transforming the electric infrastructure,” *Phys. Today*, Dec. 2004.

S.L. Hyman, et al, “America’s electric utilities—Past, present and future,” Public Utility Reports, Inc., Arlington, VA, 2004.

National Energy Technology Laboratory (NETL), A Compendium of Modern Grid Technologies, Modern Grid Initiative, Pittsburgh, PA, June 2007.

K.E. Yeager, *The U.S. Electricity Enterprise—Past, Present and Future Prospects* (Encyclopedia of Engineering). New York: Taylor & Francis, July 2007.

## Biography

**Kurt Yeager** is the executive director of the Galvin Electricity Initiative.

